

# PROJECTION SCREEN INSTALLATION GUIDE

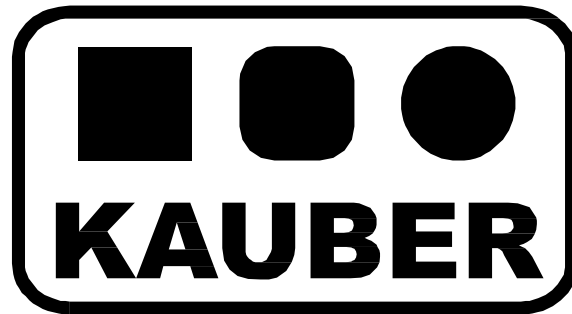

## BLUE LABEL





Blue Label is a series of electric projection screens in anodized aluminum housings. A timeless design and a wide selection of projection surfaces make it the most-chosen screen for home theater and conference rooms. In the Tensioned version it is additionally equipped with a special system of tensioners to get an even more tense projection surface.

## **IMPORTANT!!!** **INSTALLATION AND OPERATION NOTES**

1. The cassette and the bottom bar of the screen are protected against damage by polyurethane foam. Remove the foams protecting the bottom bar after mounting the screen.
2. The screen should be installed in a location away from moisture and strong sunlight.
3. A properly mounted screen must be absolutely levelled.
4. Use a soft, moistened cloth for cleaning. Do not use active cleaners. Protect the screen from ingress of water or other liquid inside. After cleaning, the screen should be carefully wiped to remove any residual moisture.
5. **DIMENSIONAL TOLERANCE:** Projection surface:  $\pm 20\text{mm}$ ; components  $\pm 3\text{mm}$
6. The screen / elevator cannot have connected more than one remote control at once.
7. One remote control (for ex. RC01 / RC02 / Trigger 12V / Trigger230V / IR Receiver / RS Receiver, etc.) cannot be connected at once to more than one screen, elevator, roller-blind, etc. Such connection can only be made by using the SG-2 group controller.

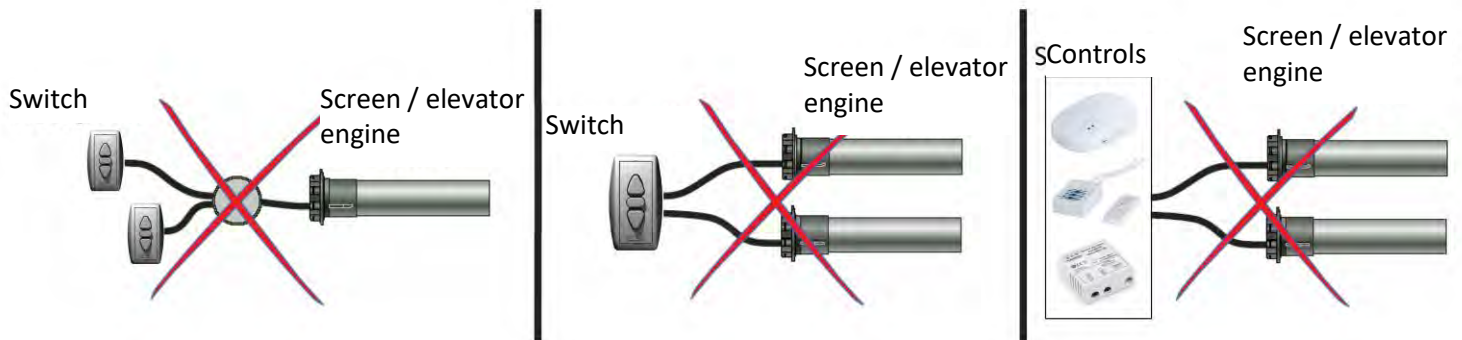

Package contents:	Qty.
Projection screen	1 pcs
Mounting bracket	2 pcs
Screws for the bracket	8 pcs
Expansion dowel Ø10	4 pcs
M6 washer	4 pcs
Wrench for adjusting the end positions of the screen	1 pcs
Wall key switch (available for screen without a built-in radio control)	1 pcs

# SCREEN INSTALLATION

1. Using the screws (c), attach mounting brackets to the sides of the screen (a) depending on the mounting method (b) in the wall position (fig. 1a) or ceiling one (fig.1b)

## Wall mounting

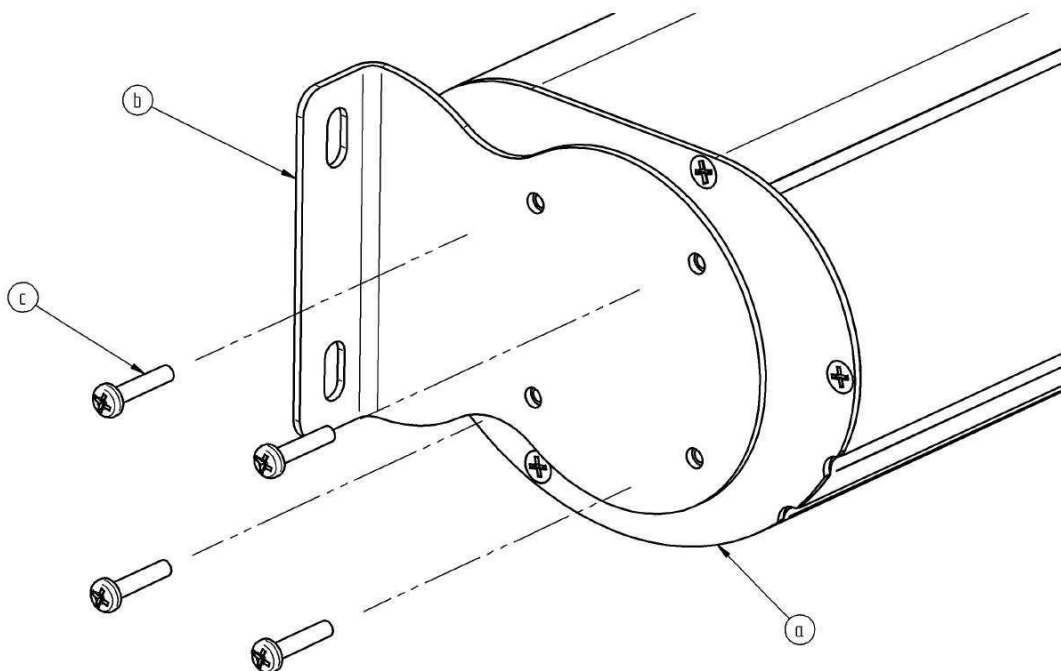

Fig.1a

## Ceiling mounting

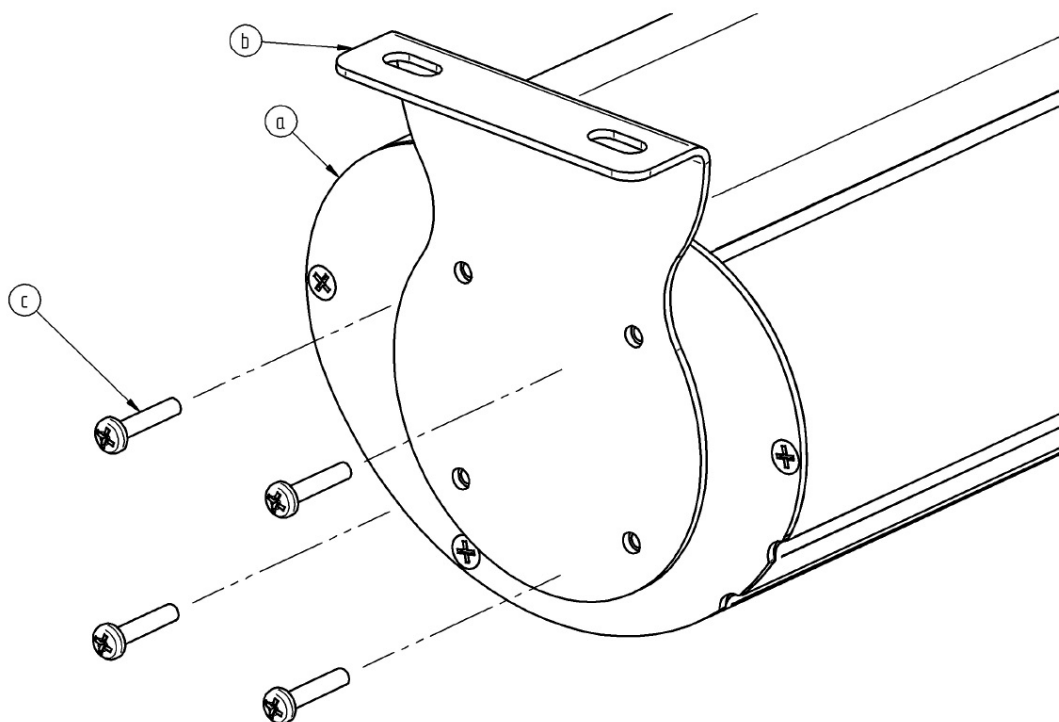

Fig.1b

- Depending on the method of mounting, screw the mounting brackets using the mounting dowels to the wall (Fig.2a) or to the ceiling (Fig.2b).

**NOTE!** The mounting dowels provided in the set can be used only for ceilings and walls made of solid materials (for ex. concrete, suporex). When attaching the screen to materials other than those listed, choose appropriate mounting dowels.

### Wall mounting

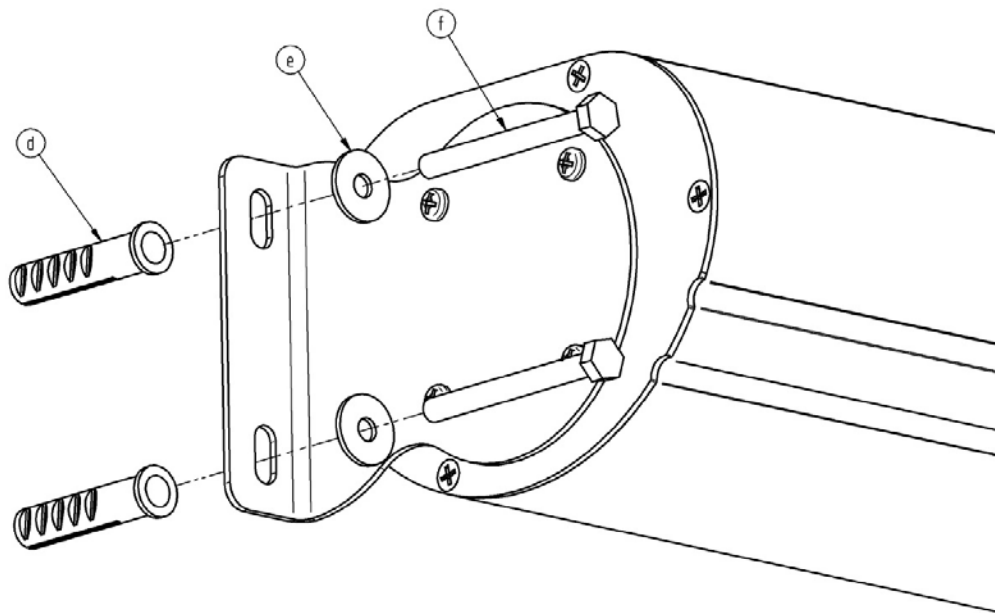

Fig.2a

### Ceiling mounting

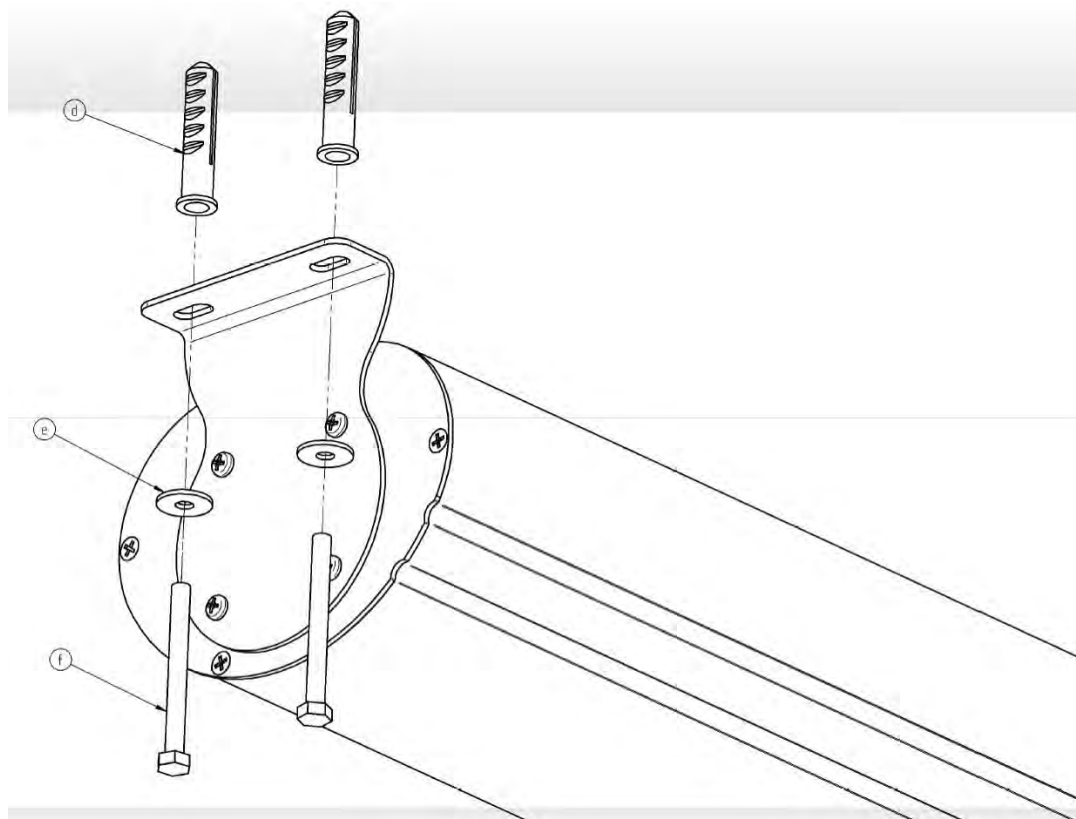

Fig.2b

3. The delivered screen has end positions set in accordance with the order. If the surface of the screen scrolls too low or not enough, correct the bottom end position using the included wrench (fig.3). **Before adjustment, check in the warranty card which type of engine your screen is equipped with.**

**NOTE!** Adjustments to the end positions can only be made by a qualified person. All adjustments are made at your own risk. In the event of an inaccurate adjustment, the screen may get damaged, which is not covered by the terms of the warranty.

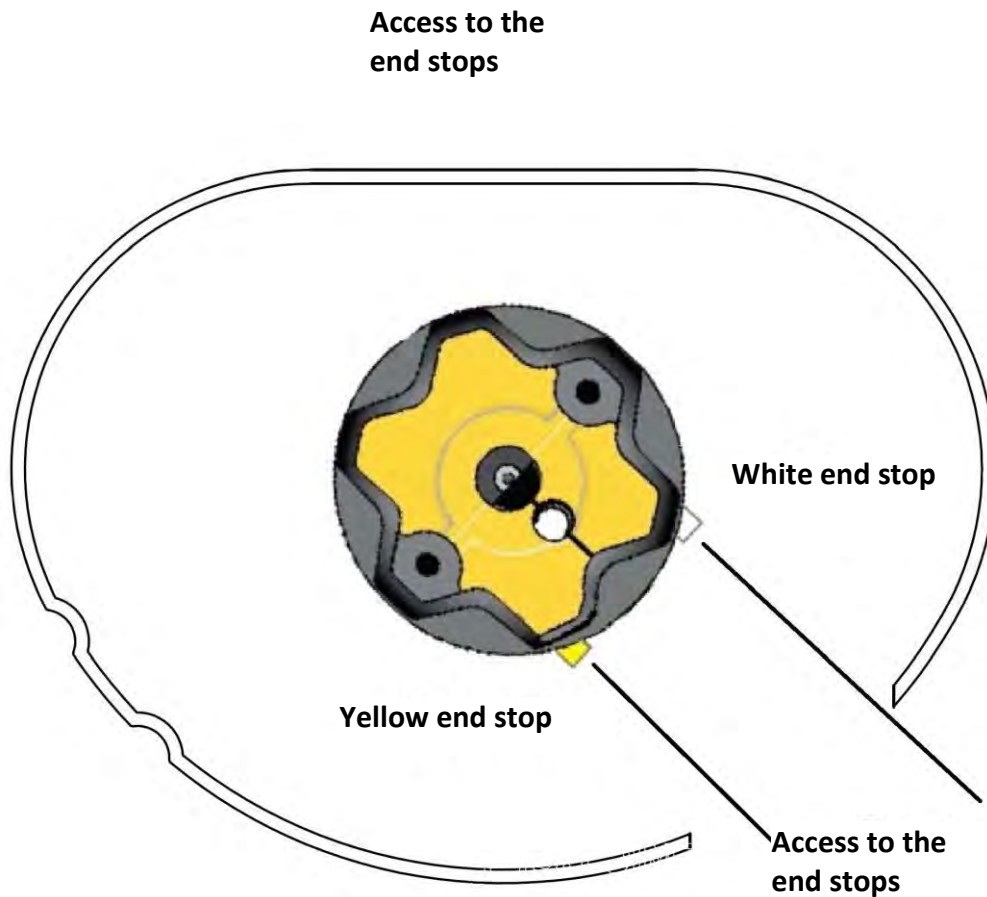

Fig.3

4. In Blue Label Tensioned screens - once the surface is fully unfolded, you can use the allen key to adjust the tensioning force (if necessary) with the screws located on both sides of the bottom bar.

**Adjusting the end positions (engine type "C" – you can check the engine type in the warranty card )**

-Correcting the top end position (white end stop).

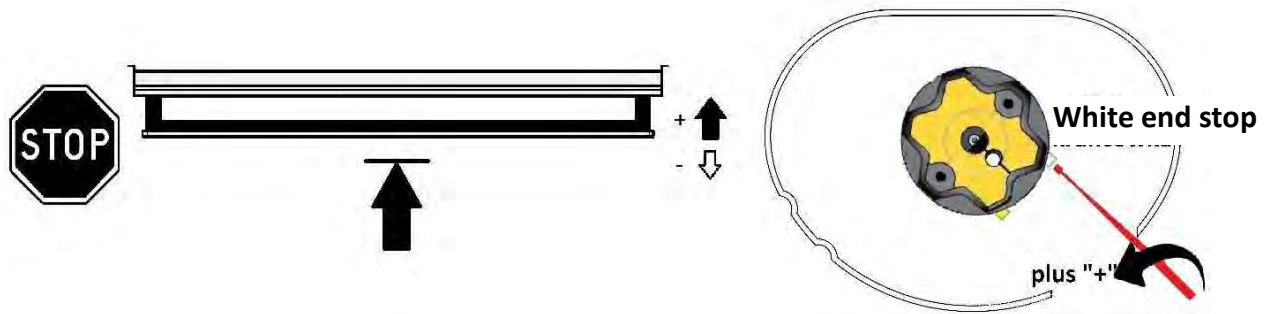

Fig.4

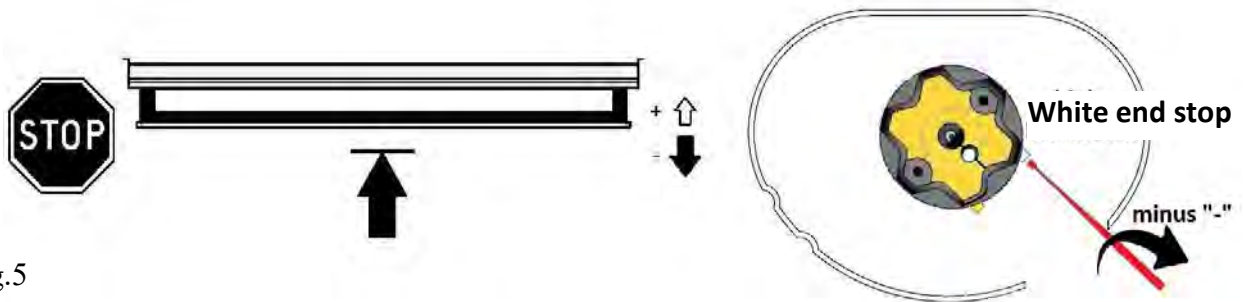

Fig.5

-Correcting the bottom end position (yellow end stop).

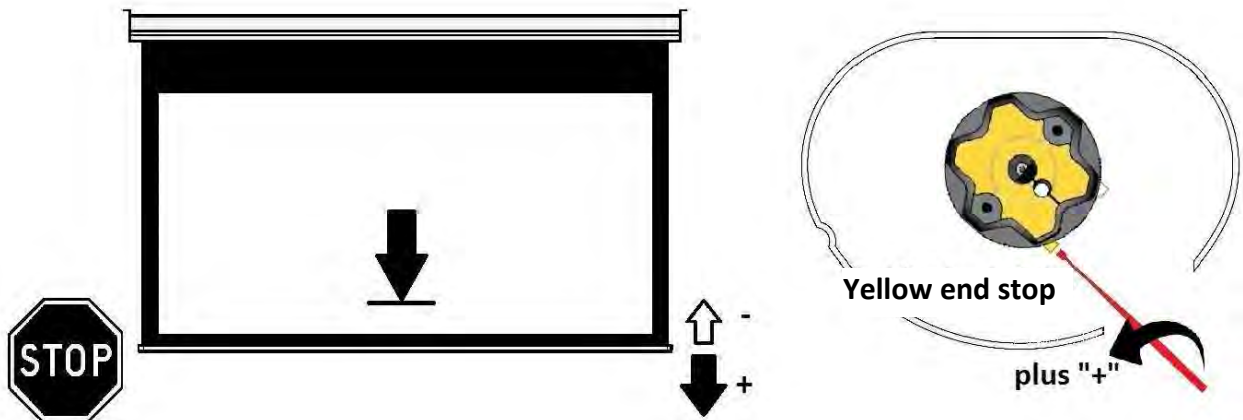

Fig.6

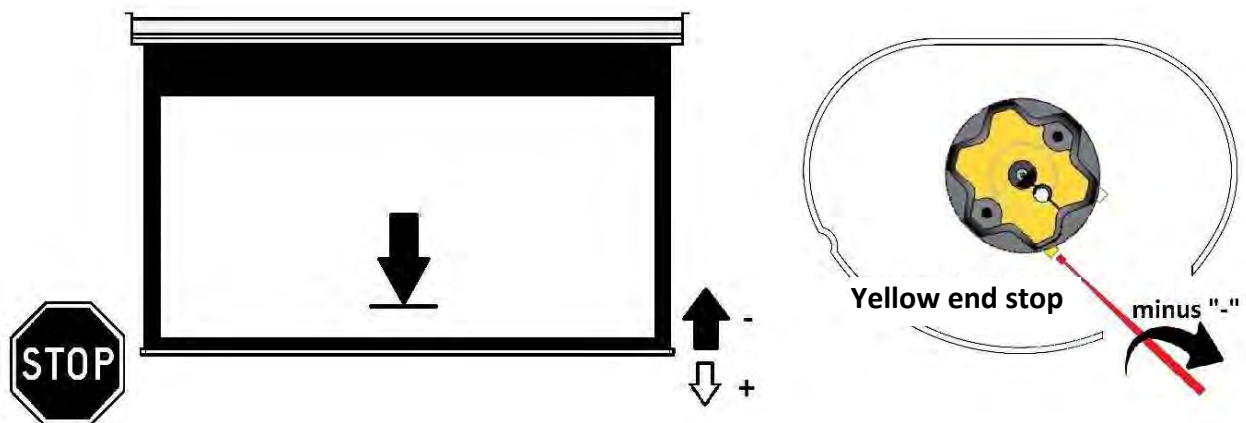

Fig.7

**Adjusting the end positions (engine type "B" and "B-RTS" - check the engine type in the warranty card))**

- Correcting the top end position (white end stop).

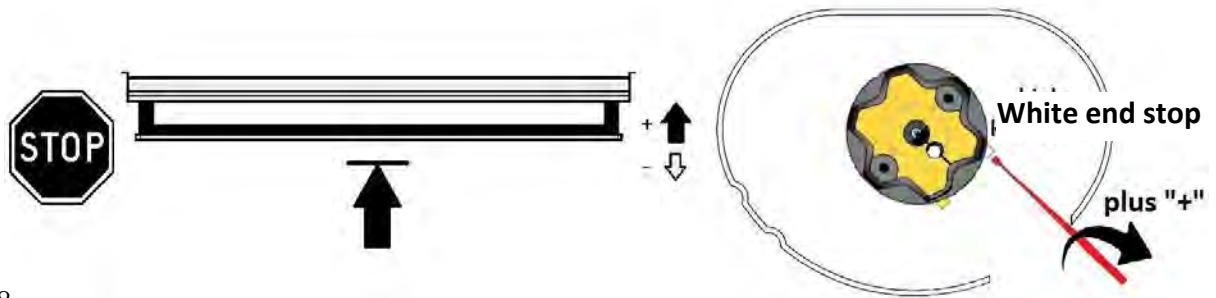

Fig.8

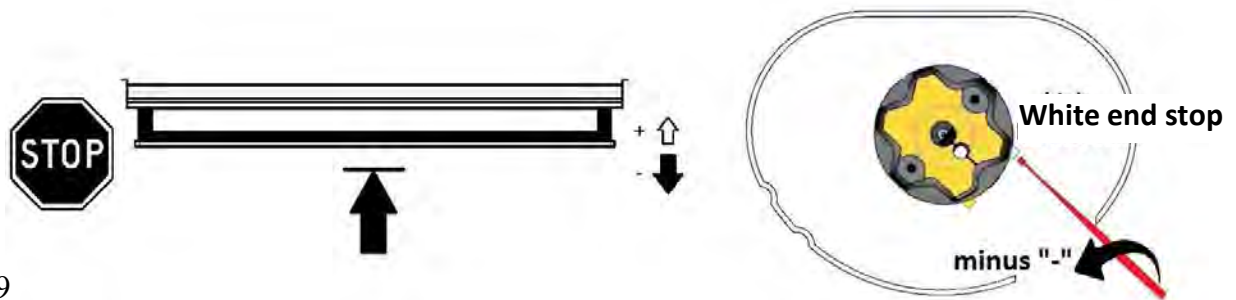

Fig.9

- Correcting the bottom end position (yellow end stop).

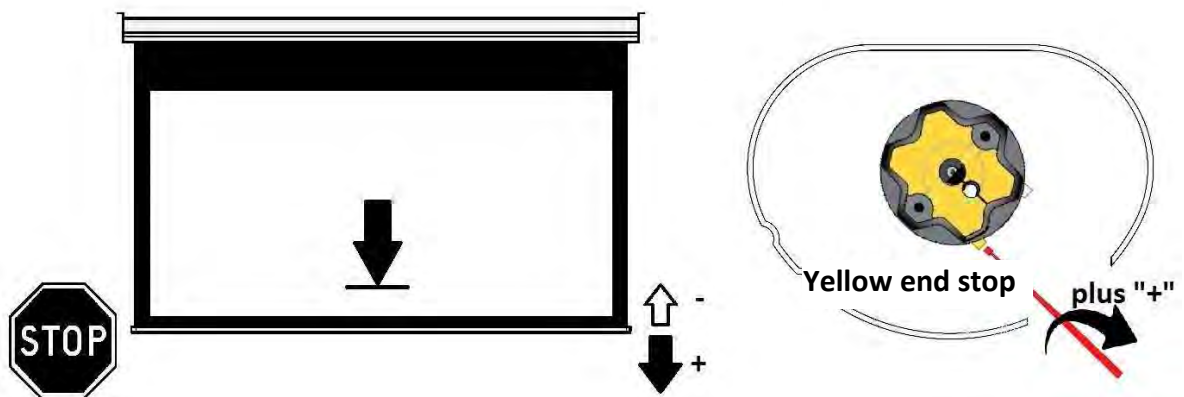

Fig.10

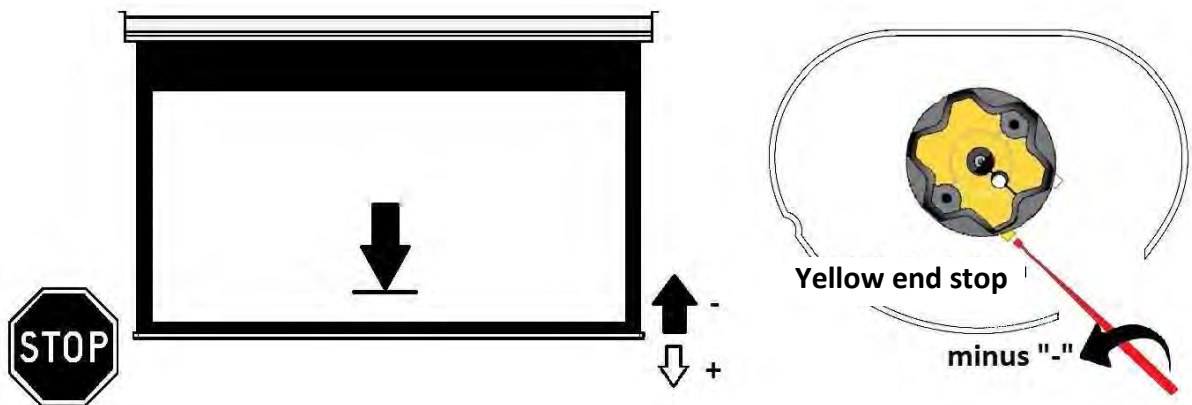

Fig.11



## End positions adjustment (screen with built-in radio control – engine type "C-RTS")

Correcting the **bottom** end position:

1. Using the remote control button **UP** set the roller-blind in the top end position.
2. At the same time, press and hold for more than 5 seconds buttons **UP** and **DOWN**. The drive moves briefly up / down.
3. Using the buttons **UP**, **DOWN**, **STOP**, set the roller-blind in the new end position.
4. Press and hold the button **STOP** for more than 2 seconds The drive moves briefly up / down

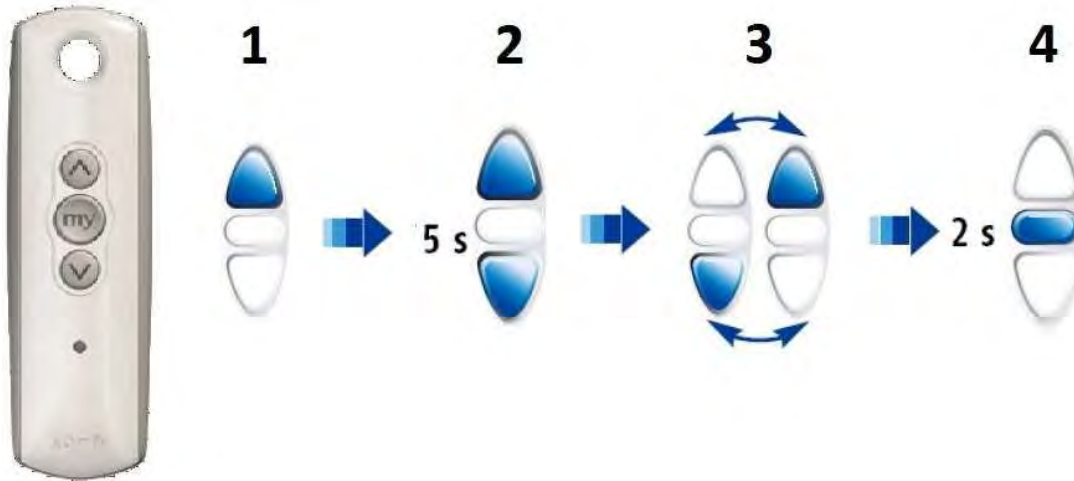

Fig. 12

Correcting the **bottom** end position:

1. Using the remote control button **DOWN** set the roller-blind in the bottom end position.
2. At the same time, press and hold for more than 5 seconds buttons **UP** and **DOWN**. The drive moves briefly up / down.
3. Using the buttons **UP**, **DOWN**, **STOP**, set the roller-blind in the new end position.
4. Press and hold the button **STOP** for more than 2 seconds The drive moves briefly up / down

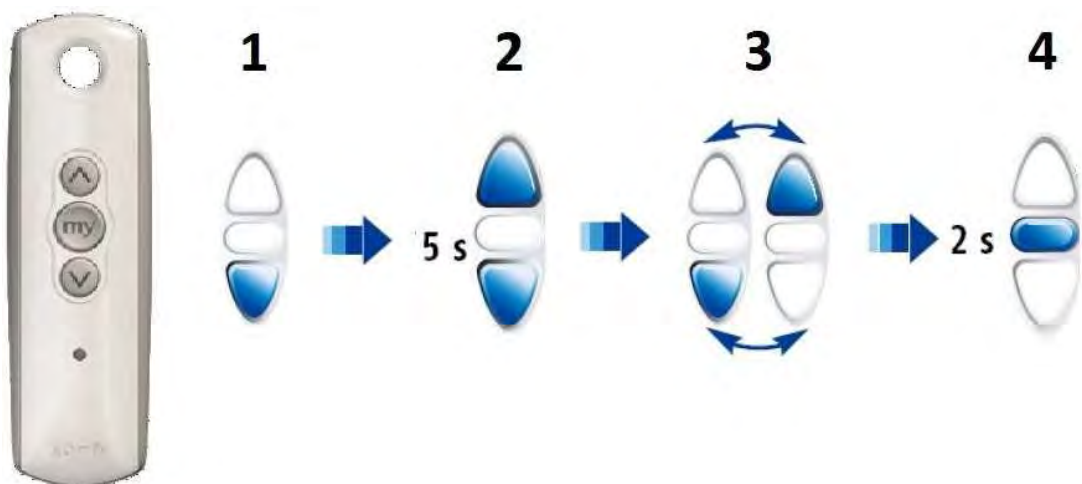

Fig.13

## NOTE!

The screen may only be connected to the power supply by a person with appropriate electrical qualifications.

Before installing the screen cassette, lead the power supply cable to the place of installation and then connect it to the screen during installation according to the diagram A (Fig.14A) or according to the diagram B in the case of a screen with built-in radio control (Fig.14B).

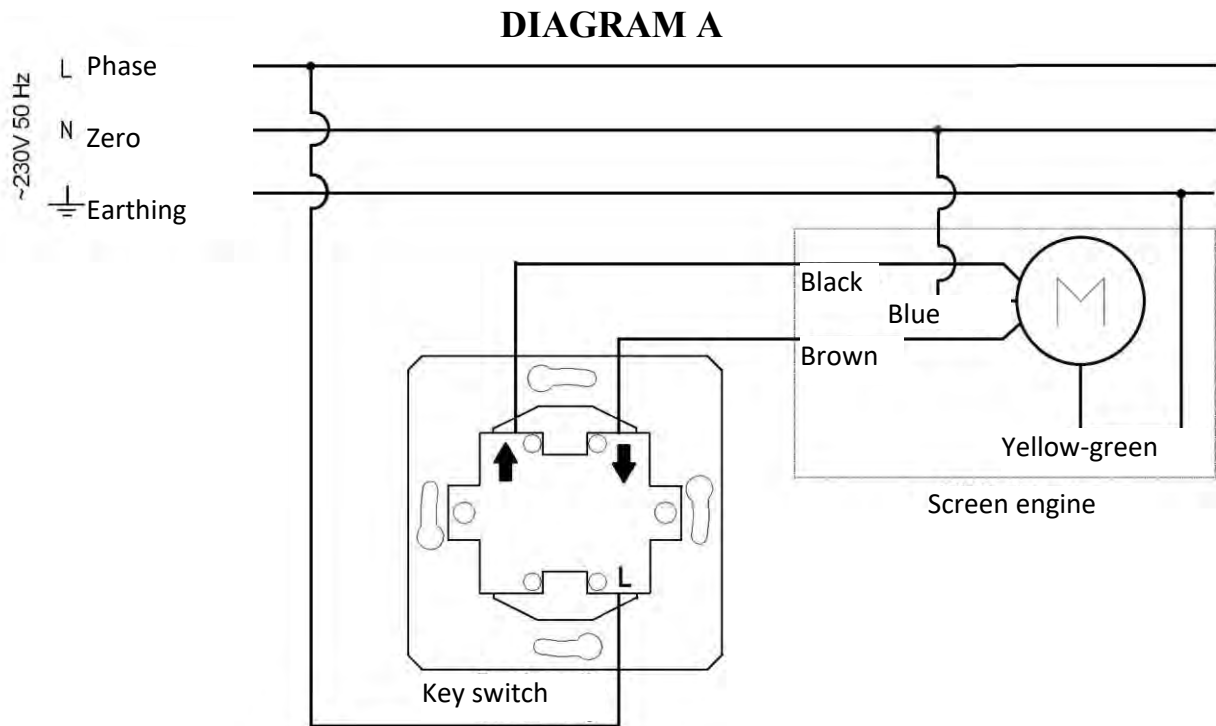

Fig. 14A

## DIAGRAM B (built-in radio control)

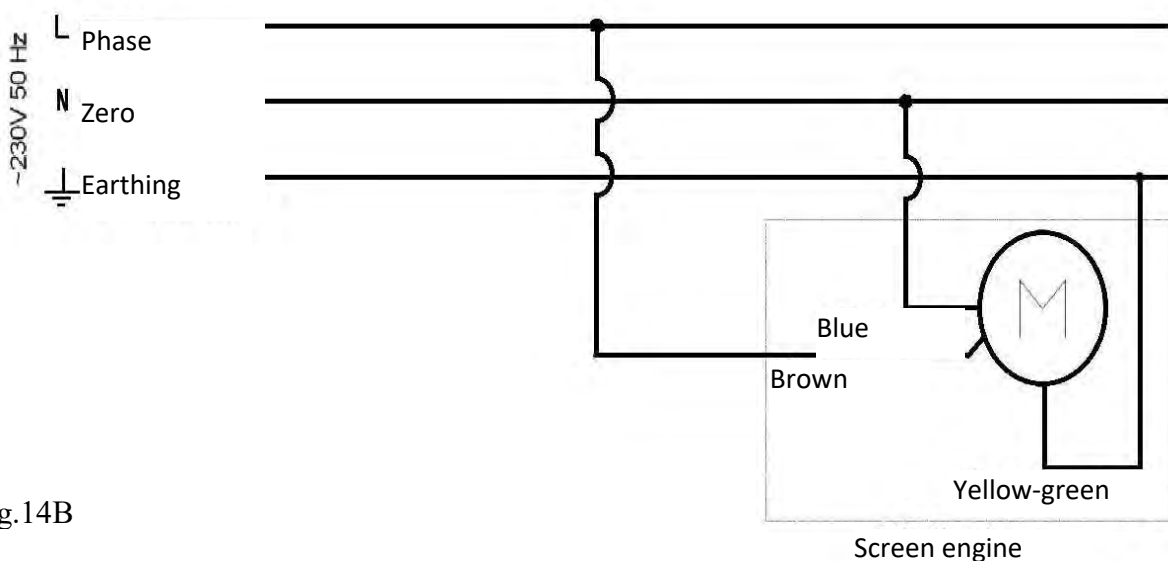

Fig.14B

### Connecting a key switch from the set.

(The switch is available in the set for screen without a built-in radio control)

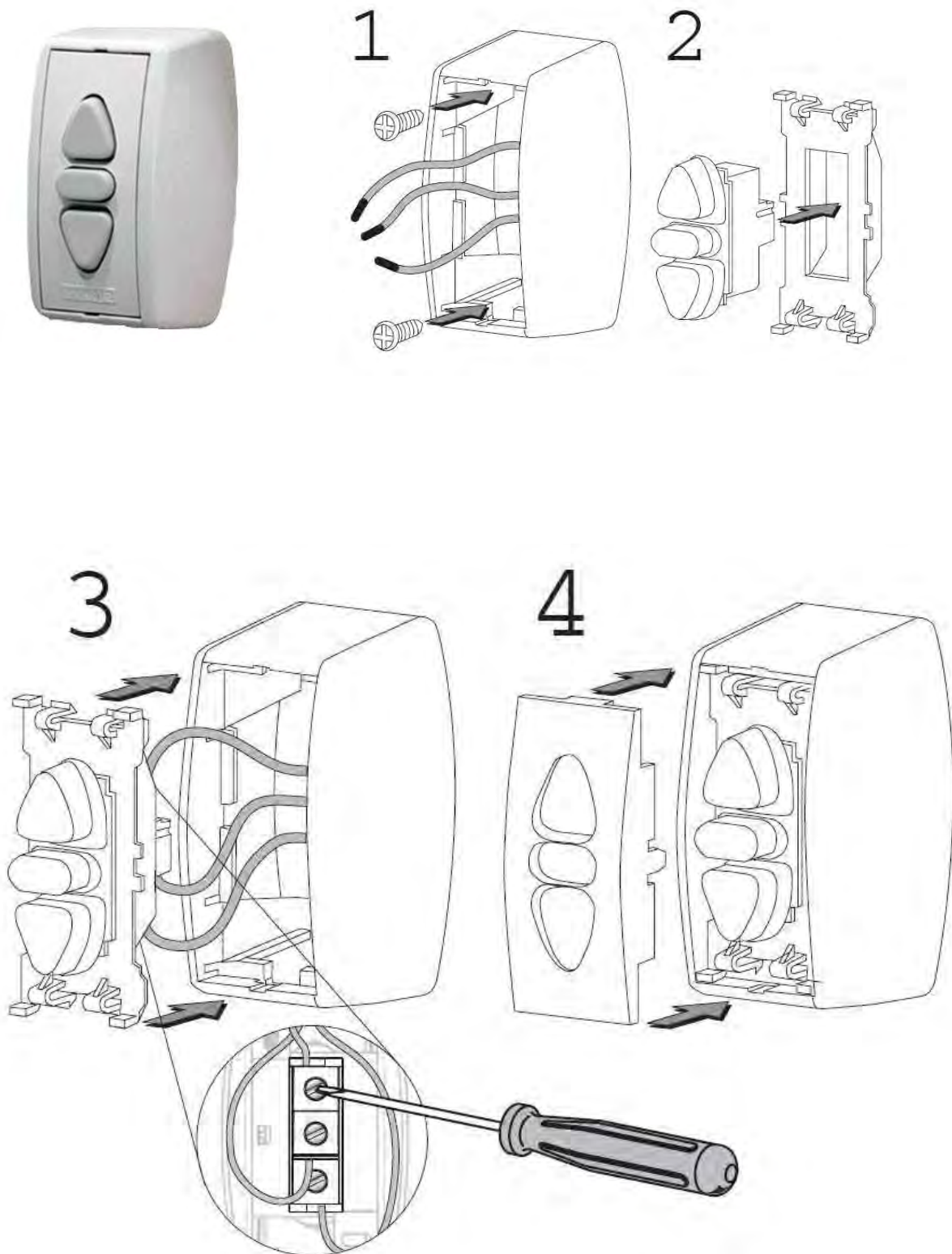

Fig.15

# Diagram of connecting a key switch to the screen (screens with a "B" and "C" type engine)

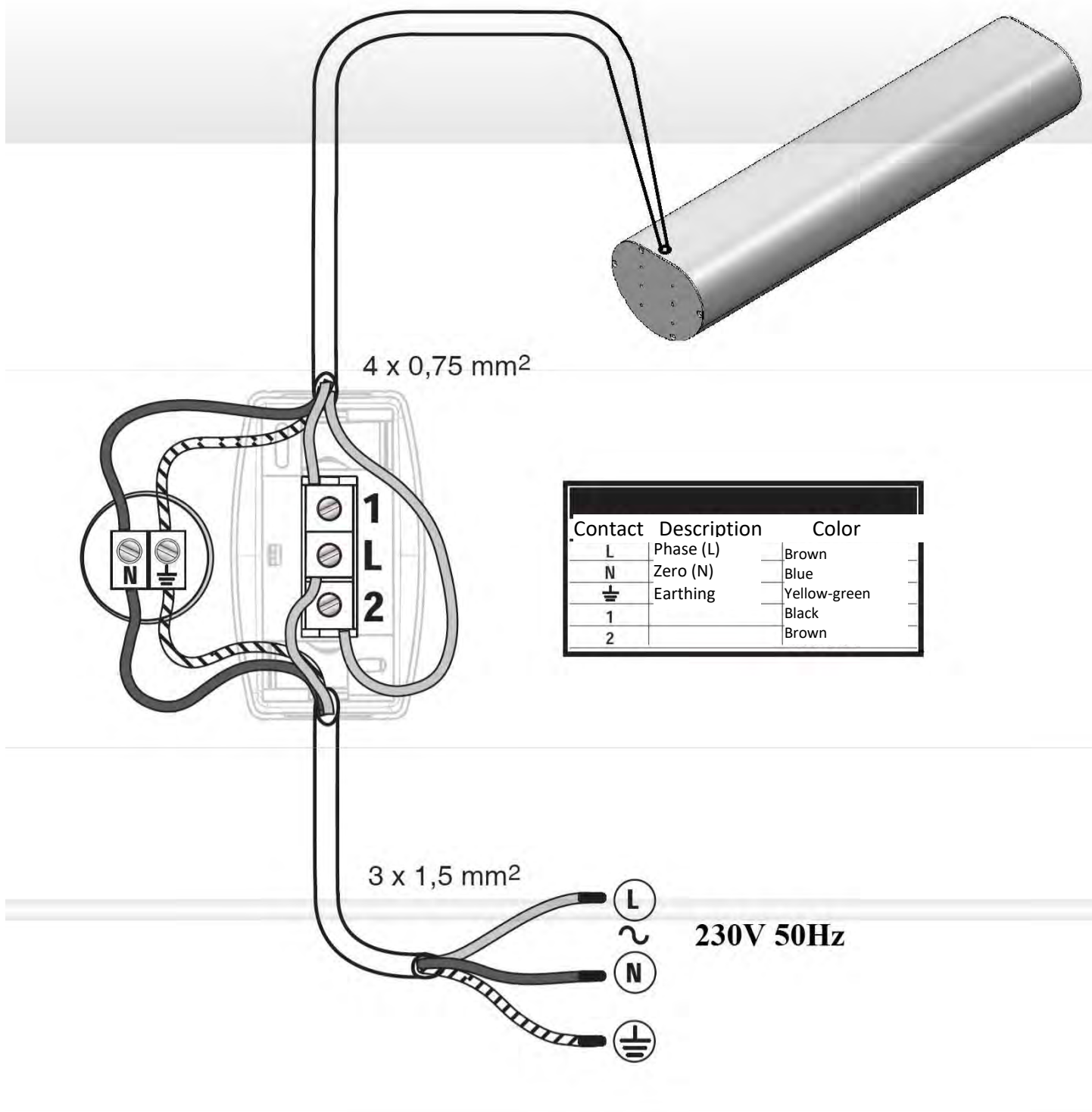
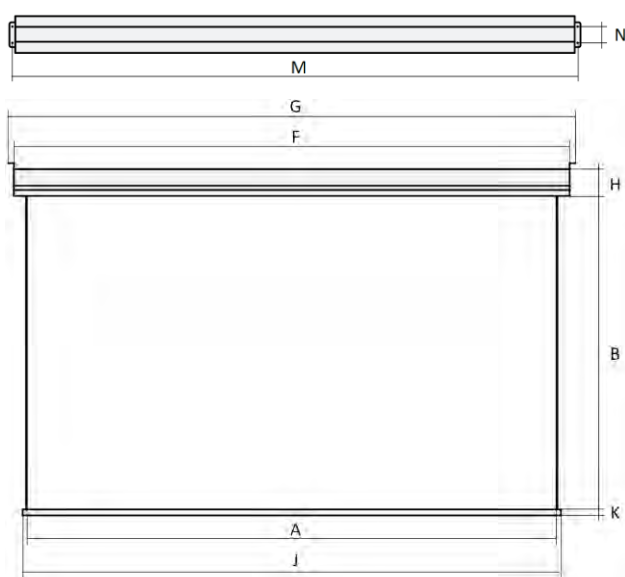
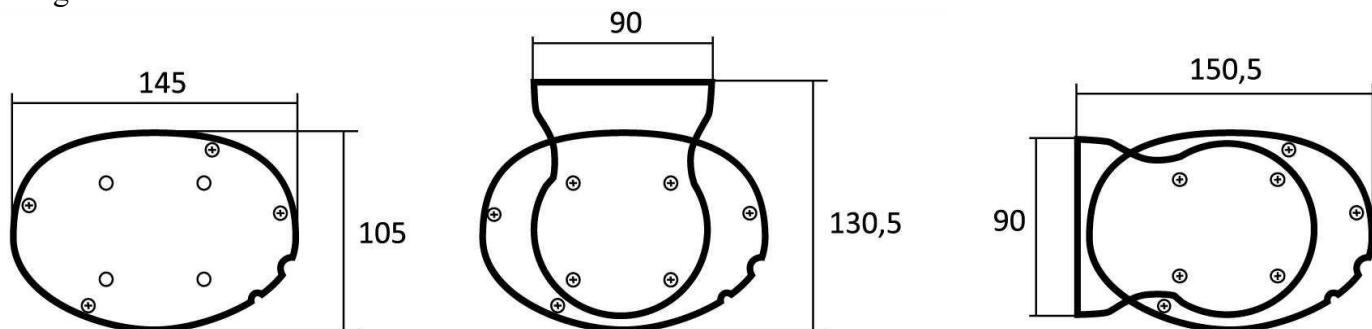

Fig.16

# TECHNICAL DATA

Housing dimensions:



**BLUE LABEL**  
 A- surface width  
 B- surface height  
 $F = A + 64\text{mm}$   
 $J = A + 30\text{mm}$   
 $K = 50\text{mm}$   
 $H = 105\text{mm}$   
 $G = A + 112\text{mm}$   
 $M = A + 88\text{mm}$   
 $N = 60\text{mm}$

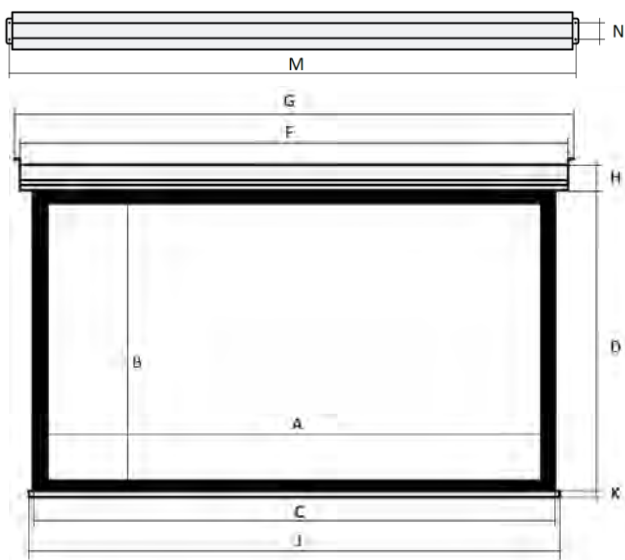

**BLUE LABEL + BLACK FRAME**  
 A- width of active surface  
 B - height of active surface  
 $C = A + 100\text{mm}$   
 $D = B + 100\text{mm}$   
 $F = A + 164\text{mm}$   
 $J = A + 130\text{mm}$   
 $K = 50\text{mm}$   
 $H = 105\text{mm}$   
 $G = A + 212\text{mm}$   
 $M = A + 188\text{mm}$   
 $N = 60\text{mm}$

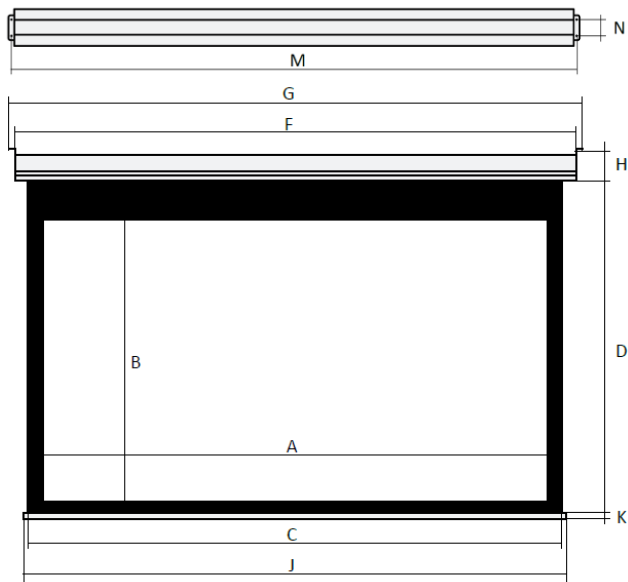

**BLUE LABEL + BLACK FRAME + BLACK STRIP**

- A- width of active surface
- B - height of active surface
- $C = A + 100\text{mm}$
- $D = B + 50\text{mm} + \text{height of the black strip}$
- $F = A + 164\text{mm}$
- $J = A + 130\text{mm}$
- $K = 50\text{mm}$
- $H = 105\text{mm}$
- $G = A + 212\text{mm}$
- $M = A + 188\text{mm}$
- $N = 60\text{mm}$

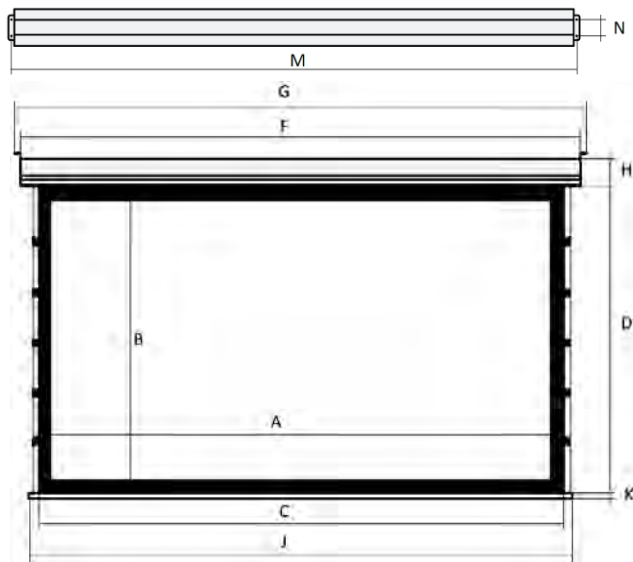

**BLUE LABEL + TENSIONERS**

- A- width of active surface
- B - height of active surface
- $C = A + 100\text{mm}$
- $D = B + 100\text{mm}$
- $F = A + 316\text{mm}$
- $J = A + 270\text{mm}$
- $K = 50\text{mm}$
- $H = 105\text{mm}$
- $G = A + 368\text{mm}$
- $M = A + 340\text{mm}$
- $N = 60\text{mm}$

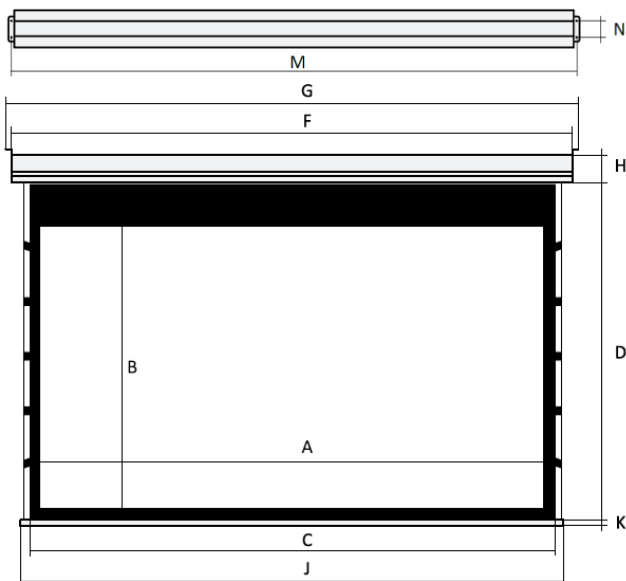

**BLUE LABEL + TENSIONERS + BLACK STRIP**

- A- width of active surface
- B - height of active surface
- $C = A + 100\text{mm}$
- $D = B + 50\text{mm} + \text{black strip height}$
- $F = A + 316\text{mm}$
- $J = A + 270\text{mm}$
- $K = 50\text{mm}$
- $H = 105\text{mm}$
- $G = A + 368\text{mm}$
- $M = A + 340\text{mm}$
- $N = 60\text{mm}$

**Technical specifications:**

Power supply: 230V 50Hz

Power: 120W – screen without a built-in radio control  
120W – screen with built-in radio control

Thank you for choosing the KAUBER screen.  
We invite you to purchase other KAUBER products

w w w . k a u b e r . e u